



## MANUAL FAIL-SAFE SPRING UNITS



*The new Kinetrol Manual Fail Safe Spring Unit/ Deadman's Handle offers a robust, reliable, weatherproof, 90° spring unit with metal handle for fail-safe manual operation of valves etc.*

### FEATURES

- ◆ Manual unit cannot be left in the wrong position. ◆
- ◆ Reliable torque delivery for positional reset. ◆
- ◆ Weatherproof sealed spring housing. ◆
- ◆ Clockwise or counter clockwise spring action. ◆
- ◆ Tough corrosion resistant Epoxy paint. ◆
- ◆ Available in factory adjusted torques from 1.4 Nm to 45.5 Nm. ◆

### ORDERING CODES/TORQUES

MODEL NO.	DESCRIPTION	NO. OF SPRINGS	MAXIMUM TORQUE NM	REDUCED TORQUE THROUGH SPRING NM
020-020-1006	02 CW FAIL SAFE UNIT	1	5.1	1.0
020-030-1006	02 CCW FAIL SAFE UNIT	1	5.1	1.0
030-020-1006	03 CW FAIL SAFE UNIT	1	14	3.0
030-030-1006	03 CCW FAIL SAFE UNIT	1	14	3.0
050-020-1006	05 CW FAIL SAFE UNIT	1	24	3.5
050-030-1006	05 CCW FAIL SAFE UNIT	1	24	3.5
050-020-1007	05 CW DOUBLE FAIL SAFE UNIT	2	45.5	5.8
050-030-1007	05 CCW DOUBLE FAIL SAFE UNIT	2	45.5	5.8

An extensive range of mount kits allows easy mounting.  
Fusible link latch options available for fail-safe positioning in case of fire.  
Contact Kinetrol for details.

# KINETROL



## MANUAL FAIL-SAFE SPRING UNITS

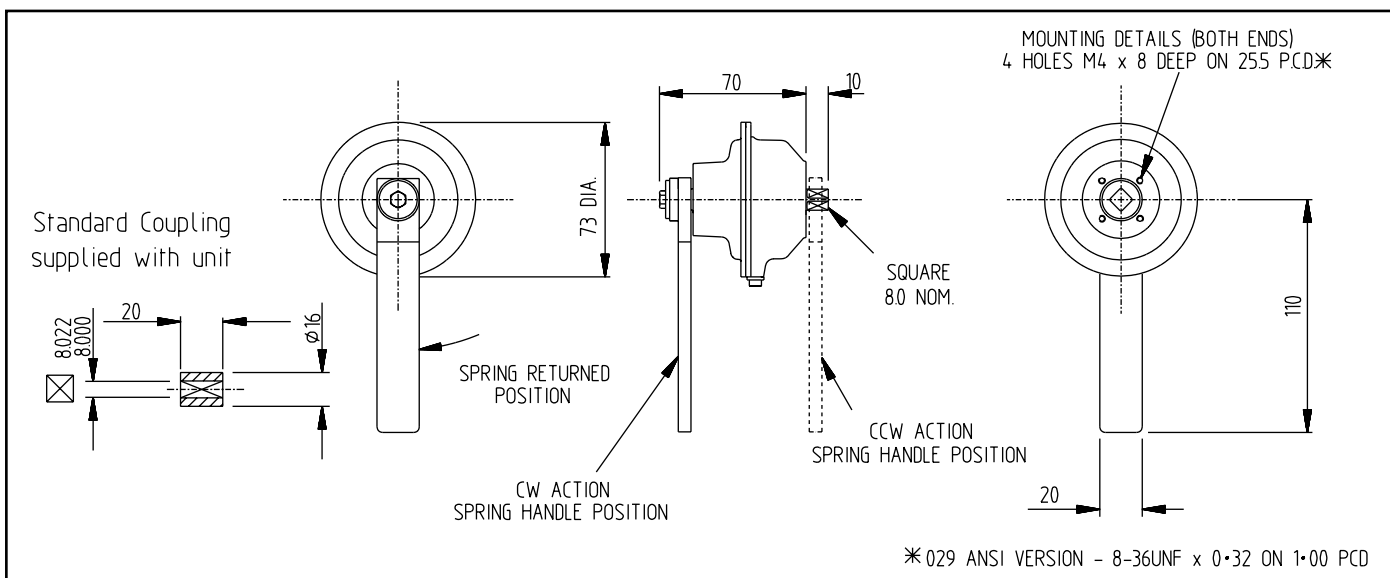
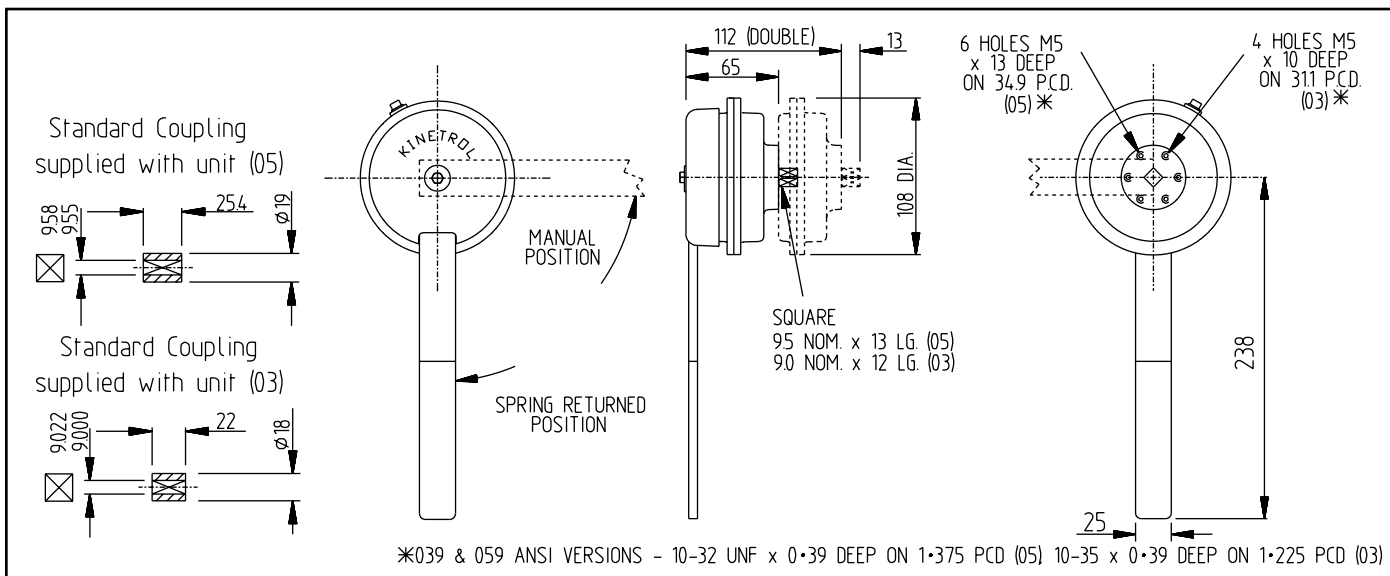

### MATERIALS

- SPRING CASE - Die cast zinc alloy with epoxy paint finish.
- COVER SHIELD - Nylon (05 Only)
- SHAFT - Stainless steel.
- LEVER - Stainless steel (03 & 05); Aluminium (02).

KINETROL LIMITED  
Trading Estate  
Farnham  
Surrey GU9 9NU  
England

# KINETROL

FLUID DASHPOTS  
PNEUMATIC ACTUATORS

Telephone: 01252-733838  
Fax: 01252-713042  
E-Mail: sales@kinetrol.com  
Web Site: www.kinetrol.com

KF 393-6/00